

AHU Kit	MODEL: TVRF-AHU2T	<b>TOSOT</b>
---------	-------------------	--------------

Job Name: \_\_\_\_\_  
 Engineer Name: \_\_\_\_\_  
 System No: \_\_\_\_\_

Location: \_\_\_\_\_  
 Contractor: \_\_\_\_\_  
 Date: \_\_\_\_\_



Specifications		Model Name
Unit Type		TVRF-AHU2T
Cooling Capacity	kW	7.1
	Btu/h	24,000
Heating Capacity	kW	8.0
	Btu/h	26,600
External Dimensions (W×HxD)	Control Box	13 1/7×11 1/6×4 3/8
	EXVBox	8×12 5/6×3 1/3
Net Weight	Lbs. / Kg	19 / 8.6
Electrical Power Requirements	Voltage, Phase, Hertz	208~230V,1ph,60
Refrigerant		R410A
Connection method		Brazing Connection
Refrigerant Piping Dimensions (In./mm)	Liquid	3/8
	Gas	5/8

Model	capacity (Btu/h)	Allowable capacity of heat exchanger (Btu/h)		Suggested air volume CFM	
		Minimum	Maximum		
TVRF-AHU2T	15,000	14,000	17,000	412	530
	18,000	17,000	21,200	530	647
	24,000	21,500	26,600	647	765

**Outline Dimension Diagram**

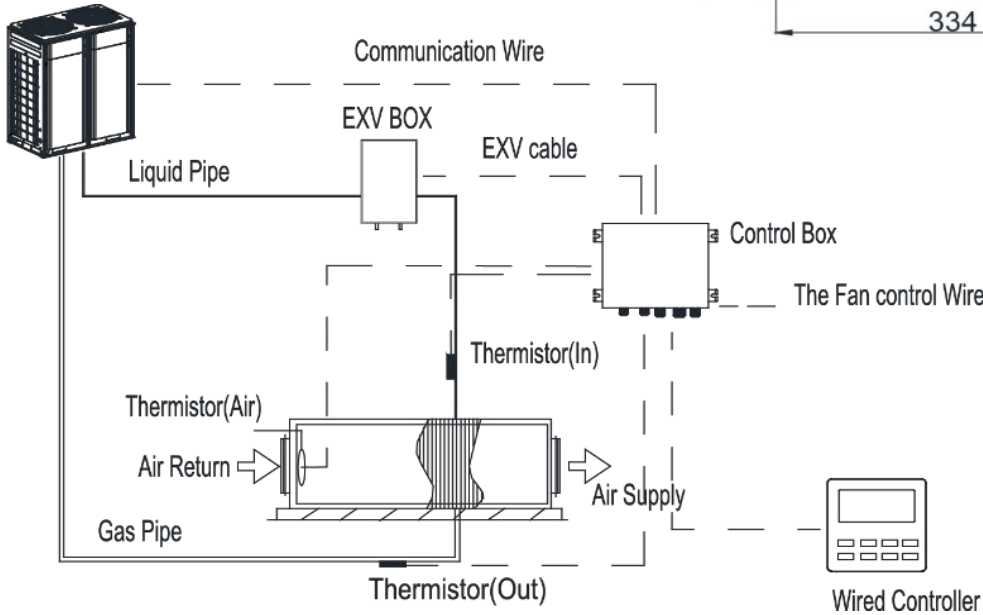
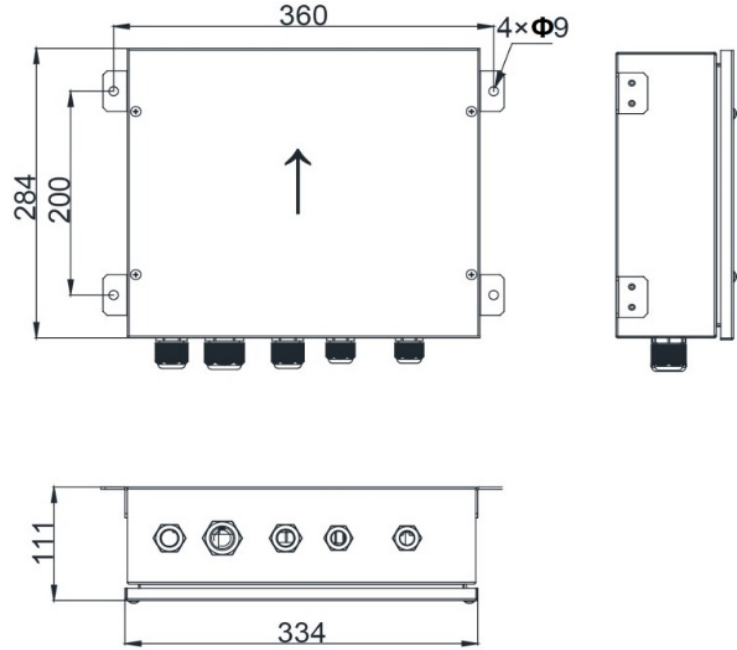

**TOSOT**

5965 Chemin de la Côte de Liesse  
Saint laurent, QC, Canada, H4T 1C3

Contact: +1 438 792 1956

[info@tosotusa.com](mailto:info@tosotusa.com)

[www.tosotusa.com](http://www.tosotusa.com)